

# **A Tale of Three District Energy Systems: Metrics and Future Opportunities**

*Rebecca Zarin Pass, Michael Wetter, Mary Ann Piette, Lawrence Berkeley National Laboratory*

## **ABSTRACT**

Improving the sustainability of cities is crucial for meeting climate goals in the next several decades. One way this is being tackled is through innovation in district energy systems, which can take advantage of local resources and economies of scale to improve the performance of whole neighborhoods in ways infeasible for individual buildings. These systems vary in physical size, end use services, primary energy resources, and sophistication of control. They also vary enormously in their choice of optimization metrics while all under the umbrella-goal of improved sustainability.

This paper explores the implications of choice of metric on district energy systems using three case studies: Stanford University, the University of California at Merced, and the Richmond Bay campus of the University of California at Berkeley. They each have a centralized authority to implement large-scale projects quickly, while maintaining data records, which makes them relatively effective at achieving their respective goals. Comparing the systems using several common energy metrics reveals significant differences in relative system merit. Additionally, a novel bidirectional heating and cooling system is presented. This system is highly energy-efficient, and while more analysis is required, may be the basis of the next generation of district energy systems.

## **Introduction**

Eighty percent of Americans live in urban environments (United States Census Bureau 2010). As such, large city infrastructure projects have enormous potential to affect progress toward sustainability goals. In the realm of energy, district heating and cooling (DHC) systems are one such type of infrastructure that is often touted for its sustainability benefits. DHC systems can provide a range of potential advantages over individually supplied utility systems. First, economies of scale allow for investment in more sophisticated systems than any individual building owner could afford or justify. This can include utilization of local renewable energy resources, maintenance-intensive systems such as biomass, ground-source heat exchange, or storage opportunities, such as downtown Toronto's use of lake water cooling (Cooper 2008; Rezaie and Rosen 2012). The centralization of equipment and control can also ease the maintenance burden at each individual building and free up space previously used for HVAC equipment (Rezaie and Rosen 2012). A second class of benefits involves complementarity, in which one building's waste energy is another's resource such that in net, the group of buildings consumes less energy together than the buildings would separately. This is a tremendous opportunity for district scale thermal energy systems. In Seattle, the waste heat from a Westin Building data center will heat the new nearby Amazon offices savings about four million kWh/year (Bhatt 2015). Finally, many industrial and hospital complexes use district energy systems to guarantee supply even when the larger utility grid has resiliency problems. This also provides new opportunities for aggregated demand response to minimize peak electric loads and provide large flexible loads to improve the integration of intermittent renewables on the electric grid.

DHC systems work best in high density, high load diversity areas. Determining the optimal levels of density and diversity and projecting where such levels will exist in the coming decades are ongoing topics of research (Nielsen and Möller 2013). Coupling this with anticipation that new, highly-efficient buildings have significantly reduced space heating and cooling loads makes prospecting the value of a DHC system quite difficult (Magnusson 2012).

In order to evaluate if district systems are a valuable investment for sustainability goals, we use metrics such as life cycle cost, greenhouse gas emissions, and energy intensity. Simultaneously optimizing for a weighted combination of these metrics results in a multi-dimensional Pareto optimization front, such as the one in Figure 1. Each project will have its own parameters that result in a unique shape of this front. External forces influence where system designers choose to be on their own Pareto fronts. Government leaders set policy targets that may come with penalties if unmet. Funding agencies incentivize projects that optimize for their particular metrics. Similarly, cities have an easier time marketing their initiatives if they are directly in line with sustainability rating agencies' metrics. These external influences are accentuated with the scale and visibility of the project. As such, these agencies are very powerful in affecting, albeit indirectly, large infrastructure projects. While low carbon intensity and low energy intensity may seem like similar metrics, they could result in entirely different implementation decisions.

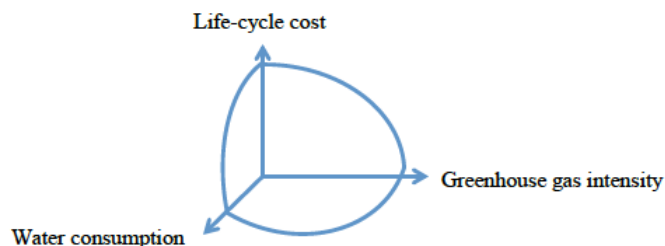

Figure 1: Visualization of a multi-dimensional Pareto front.

While some of the metrics used by such agencies to evaluate DHC systems correlate well with improved sustainability, some do not. For example, the American Council for an Energy Efficient Economy assigns 2.5% of their city energy scorecard to the mere presence or planning of district heating and cooling facilities (Mackres et al. 2015). Under this metric, New York City gets full points for its vast network of leaky steam tunnels from the 1800's. This system has a much higher energy-intensity than modern individually-sourced alternatives (Lund et al. 2014).

In this paper we seek to emphasize the importance of the specific formulation of the energy metrics agencies use to judge DHC systems. Using a case study of three California university campuses, we demonstrate how seemingly similar metrics can lead to vastly different assessments of system performance. The paper ends with a look toward the next generation of high-efficiency, bidirectional district systems and how they perform under various criteria.

### Three Campuses

As shown in Figure 2, the majority of American district heating and cooling systems are not associated with urban areas, but rather campuses, be they university, healthcare, military, or industrial. Campuses tend to have more centralized planning authority than cities, which can make it easier to zone and implement larger systems. They are also the appropriate size for

district systems, which typically serve individual neighborhoods. Additionally campuses often have more specialized buildings, which have greater incentives for enhanced resiliency systems. These include hospitals, research laboratories, high security facilities, and manufacturing facilities that are expensive to shut down.

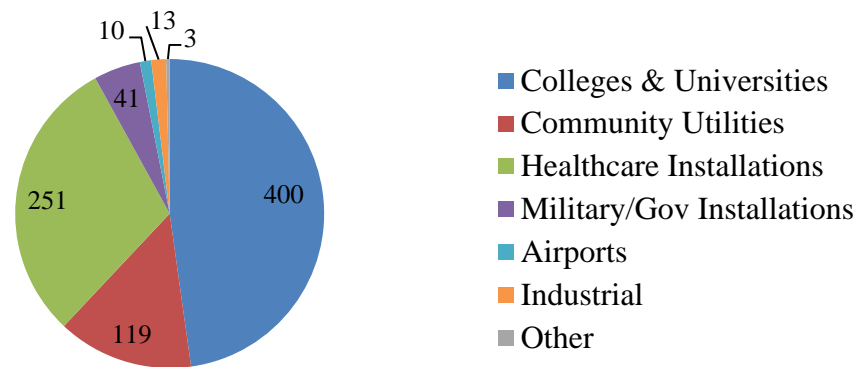

Figure 2: Number of United States DHC systems. *Source: IDEA 2009.*

University campuses, in particular, are relatively open about sharing their energy data and make for good case studies. California was chosen as a focus location in part due to its aggressive building and community energy efficiency standards. Stanford University, the University of California at Merced (UCM), and the University of California at Berkeley’s Global Campus (UCB) are each seen as leaders in sustainable energy system design. Each has policies on efficiency of new construction as well as monitoring of built infrastructure. And each made different decisions about campus energy system design.

Meanwhile, the entire University of California system has pledged to achieve net zero greenhouse gas emissions from buildings and fleets by 2025 (Budget and Capital Resources 2014).<sup>1</sup> Several of the ten UC campuses have aging infrastructure that need replacement and are looking to the new district systems to determine their own best steps forward. As such, it would be helpful to sort through the sustainability and energy performance metrics and understand how the campuses compare to each other.

### Stanford University

Stanford University used district steam heating for over 100 years. For the past three decades, a captive natural gas-fired cogeneration plant was used to supply electricity, steam, and chilled water to the campus and medical complex. With the retirement of the cogeneration plant in 2015, Stanford elected to get out of the power generation business and now purchases utility electricity, with supplement from onsite photovoltaic generation. The replacement of the steam tunnels with liquid water distribution saved 10% of their heating load from reduced distribution losses (Stegner 2014). Electric chillers supply approximately 44°F (7°C) water to the campus. Significant waste heat recovery from these chillers supplies most of the heating for a hot water loop, approximately 170°F (77°C) supply, with supplemental electric and gas boilers. A model predictive control algorithm is used to optimize the design and operation of this equipment in addition to hot and cold thermal storage reservoirs. Future development may add ground-source

<sup>1</sup> This goal applies to scope 1 and 2 emissions. By 2050, UC also pledges to be scope 3 emissions net-zero.

heat pumps and a centrally-controlled resiliency system based on electric storage rather than diesel generators (Stegner 2014). Stanford has branded this new system SESI: Stanford Energy System Innovation (shown in Figure 3). In the upcoming figures, the old system will be referred to as “Stanford cogen” and the new system as “Stanford SESI”.

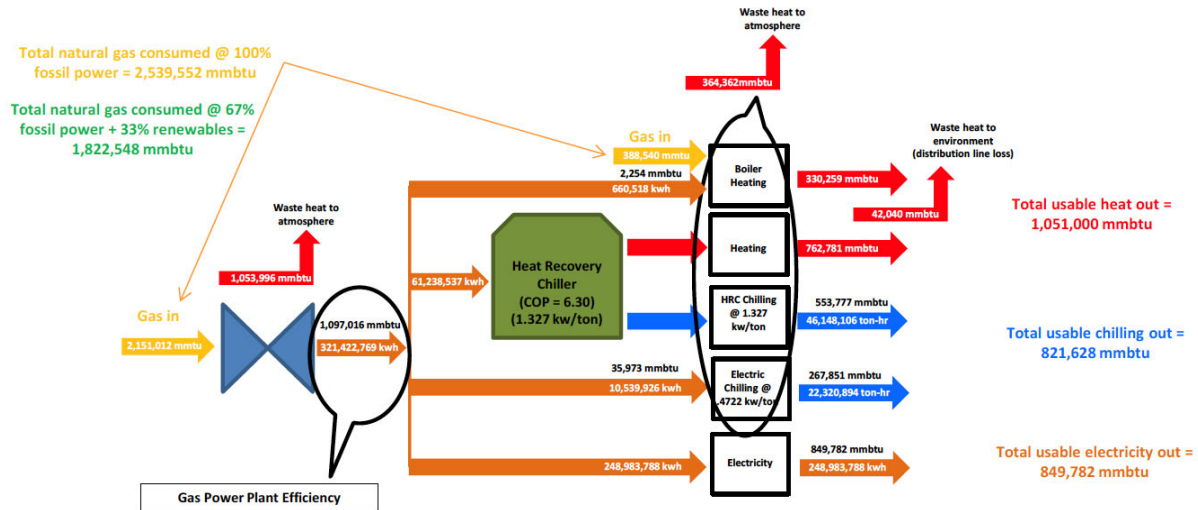

Figure 3: Schematic of Stanford SESI system. *Source:* Stegner 2014.

## UC Merced

The University of California built a new campus in Merced, opening to students in 2004. The campus was designed with a “triple zero” goal of zero net energy, zero landfill waste, and climate neutrality (Elliott and Brown 2010). This allowed the opportunity of designing the buildings together with the supply system. The district energy system is sized appropriately for intended building use, not standard building code use. However, the district system behaved as over-sized for several years while the expected buildings were still being constructed. Hot water and steam for sterilization are produced by natural gas boilers and distributed around central campus. The outer buildings have individual systems. Chilled water is produced at night, stored in a two million gallon tank, and distributed during the day at approximately 53°F/12°C (UC Merced 2016). Additionally, a monitoring-based commissioning system is used to ensure efficiency is maintained (Chancellor’s Advisory Committee on Sustainability 2014; Elliott and Brown 2010). Future development is focused on increased photovoltaic, currently 1 MW, deployment and the potential for plasma gasification for waste-to-energy systems (Chancellor’s Advisory Committee on Sustainability 2014).

## UC Berkeley – Richmond Bay

The University of California at Berkeley is planning an extension to a new site in nearby Richmond, CA. This site will be largely research-focused and as such has a significantly higher percentage of laboratory space than the other two campuses. This campus will not be completed until 2050, which provides for an interesting challenge in comparing it to the two existing campuses. The current plan is to use an ambient loop system, as seen in Figure 4, with evaporative cooling towers to provide 60°F/16°C water to all buildings (Integral Group 2015).

Because of the mild climate, this system meets the buildings' cooling needs 73% of the hours in a year. An electric chiller and thermal storage tank are used to supplement the system in other hours. For heating, each building would have a heat pump to modulate its internal air system to the necessary temperature.

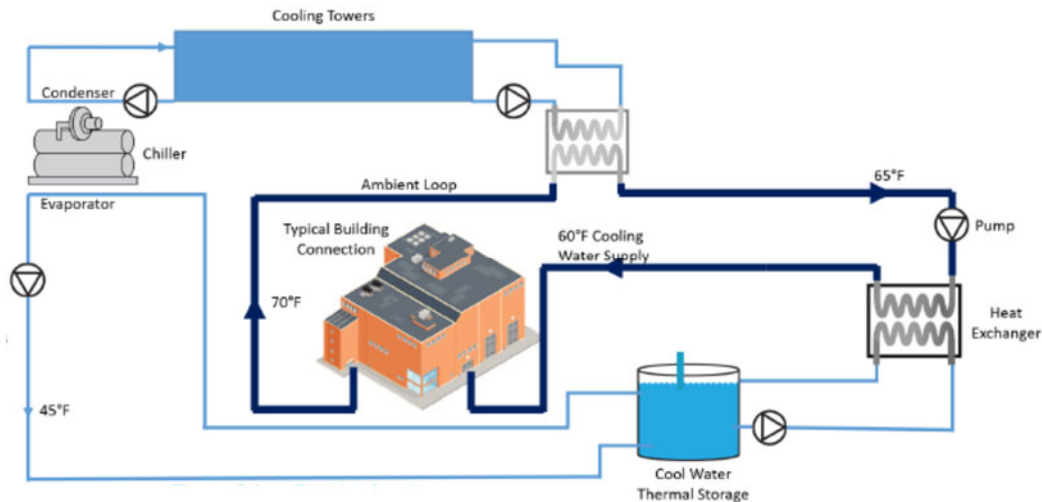

Figure 4: UCB ambient loop schematic. *Source:* Integral Group 2015.

Existing discussions of the UCB energy and water system highlight two cases: termed “base” and “aspirational”. The “base case” incorporates many high-performance features and is designed to meet the University of California’s sustainability goals. The “aspirational case” goes further, using state-of-the-art technology for all water and energy services. For precise definitions of the technologies involved in each case, please see the Infrastructure Master Plan (Integral Group 2015). UCB’s “base” vs. “aspirational” case terminology is used in the figures below.

### Campus Profile Comparison

In addition to broad sustainability goals, all three of the campuses had a few more specific incentives in common. Economics drove the decision to invest heavily in thermal storage tanks. These tanks allow for maximizing plant operations at night when electricity prices are lowest. Additionally, LEED building certification gives credit to efforts focused on “peak shaving”.

The campuses also have many differences, which provide difficulties in comparing their energy systems. First, they were built in different time frames with buildings under different energy codes. The UCB campus doesn’t exist yet and is compared as a hypothetical best guess to existing data for the others. UC Merced had its energy systems sized in expectation of its highly efficient buildings. Stanford similarly could retrofit with full operational knowledge of its building loads. However, UCB is planning its distribution system with large safety margins that are likely to result in an overly large system for the campus needs (Brown 2016). To complicate the timing matter, UC Merced and Stanford continue to evolve with new buildings and changes to the energy supply system. While all three are university campuses, as indicated in Table 1, they have different populations, different physical and building areas, and significant

differences in climate (Drake 2014; Stanford 2015; Merced 2016; Integral Group 2015). Their different primary missions are reflected in their building profiles in Figure 5, which in turn are reflected in their different energy load profiles. Thus, for any given timeframe or spatial scope, the campuses look substantially different on their assorted sustainability metrics.

Table 1: Summary Statistics

	Stanford	UCB	UCM
Data Year	2015	2050	2015
Daytime Population	33463	10000	8190
Bldg. Area (10 <sup>6</sup> ft <sup>2</sup> )	15.0	5.4	1.1
Heat/Cool °F-days. <sup>2</sup>	1847/634	2263/356	2223/1807

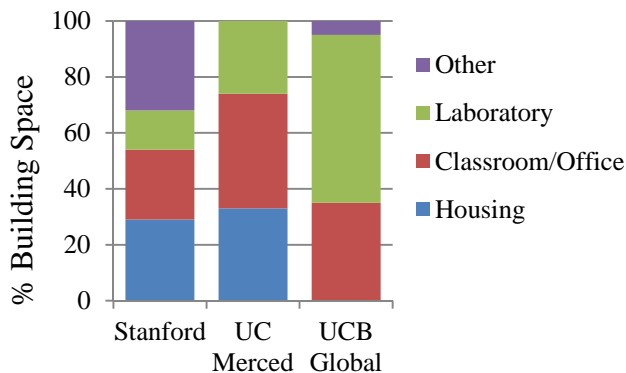

Figure 5: Building use fraction.

## Campus DHC Energy Metrics

A “campus” is not a well-specified system for accounting. In order to track resource flows, be they water, energy, dollars, pollutants, or otherwise, we need a precisely defined system boundary in both space and time. Ideally this boundary should lend itself to easy comparison between the campuses. This issue has been studied extensively, for example in the context of net zero energy buildings (Pless and Torcellini 2010; Torcellini et al. 2006) and net zero energy communities (Carlisle, Geet, and Pless 2009). Because our present focus is the district heating and cooling systems, unless otherwise stated, it is assumed that the system encompasses the processes that convert resources into hot and cold water, and then transfer this water across the campus to the buildings. It does not include the end buildings themselves, or the efficiency at which the initial resources, such as electricity, are produced.

## Coefficients of Performance

With chiller or heat pump systems, a common metric is the coefficient of performance (COP). This measures the energy of desired heating or cooling per unit of electricity supplied, by a heat pump/chiller. By the first law of thermodynamics the same system operated as a heat pump has a greater COP than the system acting as a chiller. Thus, heating and cooling COPs tend to be reported separately. However, because of different operating temperatures, in practice there are typically higher COPs for cooling systems.

All three campuses use a COP at times to describe their system. The most straightforward of these is UC Merced’s electric chiller COP, which varies around 5 (Haves 2010). Because gas boilers are used for heating, there is no COP given. UCB uses heat pumps for both heating and cooling, which allows for a COP for both modes, which are reported as a seasonal performance factor of 25 for cooling and greater than 5 for heating (Integral Group 2015). Stanford’s systems present real problems to using this metric for evaluations. First, the heat-recovery chiller provides both heating and cooling. Stanford states a combined COP of 6.3 annually for this system (Stegner 2014), which is dependent on the specific heating-to-cooling ratio. Secondly,

<sup>2</sup> Heating and cooling degree days are from 2015 weather data on a 65°F basis (Weather Underground Inc. 2016).

Stanford has an additional electric chiller without heat recovery that has its own COP, and a part-electric, part-gas boiler, which should not be described by a COP. How should this assortment of subsystems be compared with UCB's system?

Modern DHC systems that combine heating and cooling defy clear quantification with COP. Thus, benchmarking a system by this metric results in great uncertainty and potentially limits the creativity in the types of DHC designs.

### **1<sup>st</sup> Law Efficiency/Energy Use Intensity**

The easiest way around the seasonal performance factor problem is to use first law efficiencies or energy use intensities (EUI). This is more generalizable than the COP and is defined as the sum of desired energy services (heating, cooling, electricity) normalized by the provided energy or spatial footprint. This form of metric is quite commonly used for buildings and combined heat-and-power (CHP) systems. Stanford uses first-law efficiencies to evaluate both the old cogeneration system and the new SESI system. Figure 6 shows the first law efficiencies of the UCB and Stanford heating and cooling conveyance systems. This is strictly a measure of how well the system heats and cools water networks, and then moves this water to the required building end loads. It does not include the efficiency of the buildings themselves, or the efficiency in creating electricity used by chillers and heat pumps. For the conveyance system itself, which is largely the focus when discussing DHC systems, the UCB ambient loop has a far higher first-law efficiency than either Stanford's old or new system.

The first-law efficiency or EUI combines resources of substantially different energy qualities and environmental consequences as if they were equal. When doing this, it is possible to get an efficiency above 100%, as is true in three of the cases in Figure 6. This completely ignores the issues of how *well* a resource is being used. While either 90°F air or 300°F air could be used to heat a 70°F room, only the 300°F air could be used to boil water, sterilize equipment, or heat ten 100°F saunas and then heat the 70°F room. The hotter air has a higher quality, meaning it could be used for a larger variety of purposes. A first-law approach says that 10 Watts of heating from a small mass flow rate over a high temperature difference is equivalent to a large mass flow rate over a small temperature difference.

This issue is not resolved by evaluating systems on a source-basis. The source basis accounts for the upstream consequences of how the resource was produced. For example, by acknowledging that an electric-fired boiler required three units of natural gas per unit electricity. However, the source-basis cannot account for the downstream consequences of how well the resource is used.

### **Exergy Efficiency**

The absolute energy benchmark imposed by physics is the *exergy efficiency*. Exergy is a measure of the potential of a resource to do work. It combines elements of energy quantity and quality, which allows for better comparison between types of energy flows. Exergy efficiencies can be used to examine buildings, distribution systems, generation stations, or entire campuses. Many studies have started advocating for using exergy efficiencies to quantify and compare the performance of DHC systems (Schmidt 2014; Schluck, Kräuchi, and Sulzer, M 2015). However, in unsteady systems, this can be complicated by storage of exergy for potential use at a later time.

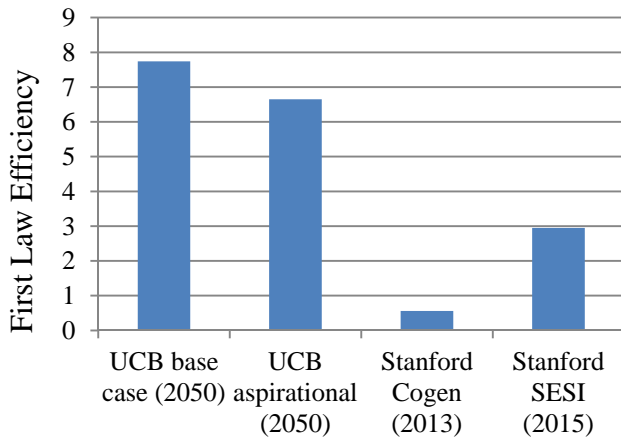

Figure 6: First law efficiency.

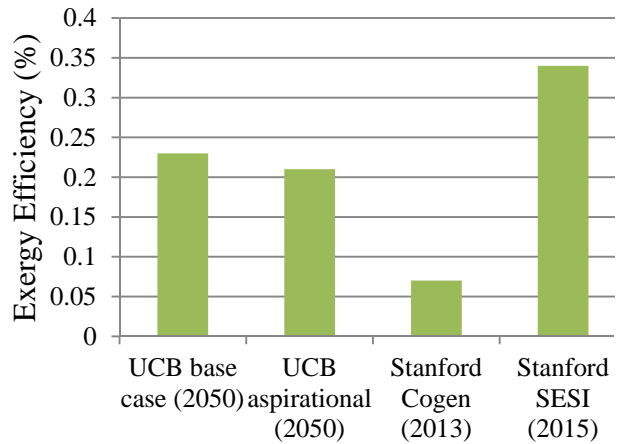

Figure 7: Exergy efficiency.

Figure 7 shows the annual exergy efficiency of the Stanford and UCB DHC systems. Because time interval data was not available, it was not possible to use an instantaneous outdoor air temperature for the dead state. Instead a fixed 59°F (15°C) is used as the dead state in Figure 7. Unlike the first-law efficiency, the exergy efficiency indicates that the new Stanford system is more efficient than either of the UCB cases.

However, a very important caveat applies, which illustrates the nuance in defining the system boundary. The Stanford system supplies much hotter hot water and much colder cold water than the UCB system. By definition, these are more exergetic resources. The exergy of a heat transfer is

$$\psi_q = q \left( 1 - \frac{T_0}{T_b} \right)$$

where  $q$  is the heat transfer energy,  $\psi_q$  is the exergy associated with the heat transfer,  $T_0$  is the dead state temperature, and  $T_b$  is the temperature of the boundary where the heat transfer occurs.

Thus, the conveyance system itself has a higher-exergy end product in the Stanford case than in the UCB case ( $T_b$  is higher for Stanford). If the buildings' internal space heating and cooling systems were also incorporated into the system boundary, the inefficiency of using 170°F (77°C) hot water to heat a 70°F (21°C) room would be revealed. This is reflected in the equation by making  $T_b$  the room temperature. To give a measure of how crucial this is, if the numbers in Figure 7 are adjusted assuming that the heat is delivered at 80°F (27°C) instead of 170°F (77°C) and the cooling is delivered at 50°F (10°C) instead of 44°F (7°C), the Stanford Cogen and Stanford SESI exergy efficiencies drop to 2% and 9%, respectively.

### Carbon Intensity

Arguably carbon intensity metrics have even more nuanced issues of system boundary. Carbon emissions are often described as being contained in scope 1, 2, or 3. Scope 1 accounts for direct emissions within the physical boundary, which as discussed is in itself non-trivial. Scope 2 also accounts for emissions associated with electricity production offsite. Scope 3 encompasses all other offsite emissions, including product manufacturing (Kramers et al. 2013). In their study of eight U.S. cities, Hillman and Ramaswami (2010) found that ignoring scope 3 emissions underestimated cities' greenhouse gas footprints by 47%.



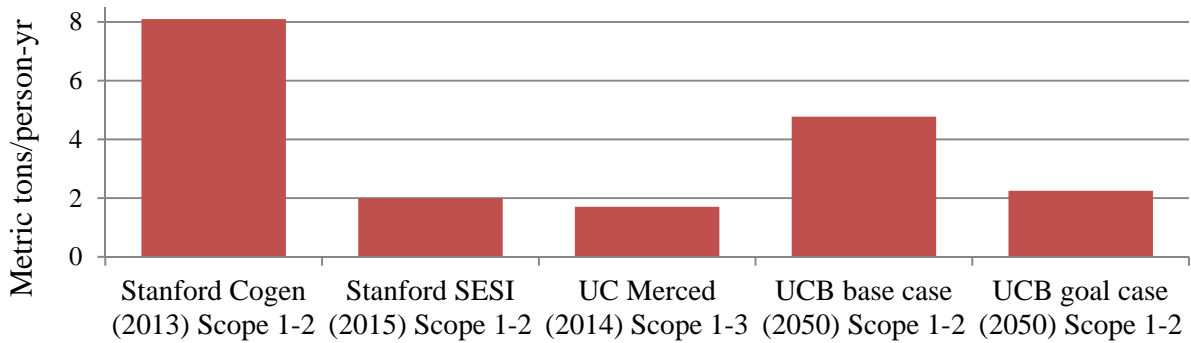

Figure 8: Per capita carbon intensity.

Figure 8 shows the reported carbon emissions of each of the campuses. Because of reporting methods, these do not isolate the district heating and cooling systems on those campuses, but show the emissions associated with the campus physical boundaries. As is often the case, insufficient data does not allow for a clean comparison at the same time point with the same emissions scope. To be as clear as possible, dates and scopes are included in the graph. Unfortunately, even declaring the emissions scope does not define the accounting methodology.

To its credit, UC Merced has the lowest rate of emissions and the broadest scope of accountability. Using Merced as a base of comparison then makes the goals of UCB, a campus not even yet built with the latest technology, less impressive. However the UCB system is largely dominated by laboratory space, which tends to be high-energy intensity. In their sustainability reports, Stanford and UCB tend to report their personal comparison bar graphs of how they have, or may, improve between scenarios. Comparing them to UC Merced gives a whole other perspective on how well they *could* do.

## Looking to the Future

Stanford, UC Merced and UCB are at the forefront of DHC system design. A research consortium in Switzerland is exploring an even further step forward with bidirectional energy systems (Schmidt 2014; Schluck, Kräuchi, and Sulzer 2015). Much like the electrical grid can convey energy both from a centralized generator to a consumer and back from a rooftop PV into the grid, a bidirectional thermal network uses a single pipe for both heating and cooling. When in net, more cooling is needed than heating, the system circulates from a central plant in one direction. When more heating is needed, the system circulates in the opposite direction. Like the Stanford system, a large benefit of this design is the capacity for waste-heat recovery. However in the bidirectional system, buildings can recover heat from each other *directly*, and in the case where they can meet each other's loads, no flow rate is required through the central plant.

Figure 9 shows an example schematic of a bidirectional system. The plant guarantees that the hot side is kept in a range of around 12-20°C while the cold side is kept in a range of around 8-16°C. Like the UCB ambient loop system, the bidirectional system uses near-ambient temperatures to maximize efficiency of heat pumps. Unlike central DHC, the bidirectional system need not be operated to serve the lowest and highest temperature needs. Rather, each individual building is equipped with heat pumps so that it can modulate its own chilled and hot

water loops up or down in temperature from the main network. The system has the benefit of being modular, such that more buildings can be added in time, and when necessary, additional resources.

An exergy analysis comparing the bidirectional system to a unidirectional (ambient) system with the same end loads found that the bidirectional had 1.6x the exergy efficiency of the unidirectional (Schluck, Kräuchi, and Sulzer 2015). This use of an absolute benchmark, for the same system boundary receiving the same incoming fuels and same outgoing loads at the same temperatures gives a very clear indication of the merit of the bidirectional system. These numbers have been calculated for both a numerical case study as well as an ongoing full-scale demonstration site. It remains an open research question how well this bidirectional system translates to different locations and different energy load profiles.

Additionally, there is work to be done on designing a dynamic thermal energy market in which buildings buy and sell waste heat. This will require creating a tradable commodity of waste heat in terms of some metric. Is it the thermal energy that is sold? Or a guarantee of temperature compliance? Or the thermal exergy? And if it is the exergy, at what desired end-use boundary temperature? Whatever quantification is chosen will ultimately incentivize people to maximize their utility of that specific metric. As presented above, this may or may not broadly translate to simultaneously meeting other metrics.

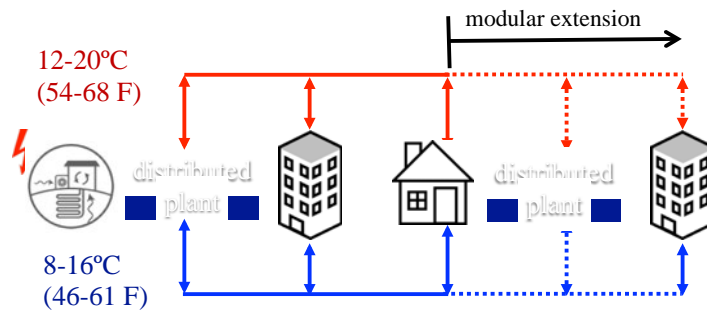

Figure 9: Simple bidirectional loop schematic.

## Conclusion

Many government and private organizations are actively encouraging the development of district heating and cooling systems through policies, funding, and expedited permitting. However, these systems are not by definition more efficient or sustainable than alternatives. Determining best steps forward is going to require careful comparisons between DHC technologies, as well as between DHC technologies and appropriate individually supplied alternatives.

Here we provide a cautionary tale of how crucial appropriate metrics are for evaluating district heating and cooling systems. In a case study of three modern California university campuses, we determined that three seemingly reasonable energy metrics result in three different evaluations of relative system merit. A carbon intensity metric favors UC Merced's campus, which also happens to be the least laboratory-intensive campus. A first-law energy efficiency metric would lead to a preference for UCB's ambient loop design. Finally, an exergy efficiency reveals the efficiency of Stanford's heat recovery system, but upon careful examination, also shows the building-side inefficiencies in its high temperature water supply.

Table 2: Summary of value of each metric.

Metric	Pros	Cons
COP	Easy to calculate & commonly used.	Assumes separate, all-electric heating and cooling.
EUI/1 <sup>st</sup> Law Efficiency	Easy to calculate & commonly used.	Conflates resources of different qualities. Incentivizes using high-exergy resources for all tasks.
Exergy Efficiency	Absolute metric against physical limits. Allows comparison btwn unlike systems.	Needs more data to calculate & less commonly used.
Carbon Emissions	Absolute metric of resulting pollution. Allows comparison btwn unlike systems.	Difficult and unclear protocol to calculate, especially for increased scope.

Given this information, we recommend that organizations evaluating thermal energy systems make careful and precise decisions about their goals and scope of comparison prior to choosing a metric. As summarized in Table 2, some of the simpler metrics (like EUI) can be adequate if the decision is truly between alternate systems using the same resource to provide a uniformly fixed ratio of heating, cooling, and electricity. This will sometimes be the case for individual system operators. However larger sustainability ratings organizations will often be comparing a broader array of systems. This requires a more flexible metric, such as exergy efficiency or carbon emissions of a specified scope. Without this translatability, metrics will have unintended consequences of incentivizing the use of high-grade resources of unspecified pollutant levels to provide low-grade end services.

## Acknowledgments

This work was supported by the Assistant Secretary for Energy Efficiency and Renewable Energy, Building Technologies Office, of the U.S. Department of Energy under Contract No. DE-AC02-05CH11231. The authors thank Karl Brown at the California Institute for Energy and Environment and John Elliott at Lawrence Berkeley National Laboratory for their input.

## References

- Bhatt, S. 2015. “Amazon, Data Center Turn Hot Idea into Cool Technology.” *The Seattle Times*, November 12. <http://www.seattletimes.com/business/real-estate/amazon-towers-will-be-heated-by-neighbors-excess-energy/>.
- Budget and Capital Resources, Office of the President. 2014. “Annual Report on Sustainable Practices.”
- Carlisle, N., O. Van Geet, and S. Pless. 2009. “Definition of a ‘Zero Net Energy’ Community.” *NREL/TP-7A2-46065*.
- Chancellor’s Advisory Committee on Sustainability. 2014. “Sustainability Progress Report.”
- Cooper, L.T. 2008. “An Evaluation of District Energy Systems in North America.” 60–72.

- Drake, E. 2014. “Stanford Population Report : Fall 2014 ( FY15 ).”  
<https://web.stanford.edu/dept/pres-provost/irds/ir/analytical-reports/population/population-report-FY15.pdf>.
- Elliott, J., and K. Brown. 2010. “Not Too Fast , Not Too Slow.” *Proceedings of ACEEE 2010 Summer Study*.
- Haves, P. 2010. “Model Predictive Control of HVAC Systems.” LBNL-3906E.  
<http://escholarship.org/uc/item/3pt2d32h>.
- Integral Group. 2015. “Berkeley Global Campus at Richmond Bay: Infrastructure Master Plan.”.
- Kramers, A., J. Wang, S. Johansson, M. Höjer, G. Finnveden, and N. Brandt. 2013. “Towards a Comprehensive System of Methodological Considerations for Cities’ Climate Targets.” *Energy Policy* 62: 1276–87.
- Lund, H., S. Werner, R. Wiltshire, S. Svendsen, J.E. Thorsen, F. Hvelplund, and B.V. Mathiesen. 2014. “4th Generation District Heating (4GDH).” *Energy* 68: 1–11.
- Mackres, E., K. Johnson, A. Downs, R. Cluett, and K. Schultz. 2015. “The 2015 City Energy Efficiency Scorecard.” ACEEE.
- Magnusson, D. 2012. “Swedish District Heating-A System in Stagnation: Current and Future Trends in the District Heating Sector.” *Energy Policy* 48: 449–59.
- Merced, UC. 2016. “Fast Facts.” Accessed February 16. <http://www.ucmerced.edu/fast-facts>.
- Nielsen, S., and B. Möller. 2013. “GIS Based Analysis of Future District Heating Potential in Denmark.” *Energy* 57: 458–68.
- Pless, S., and P. Torcellini. 2010. “Net-Zero Energy Buildings : A Classification System Based on Renewable Energy Supply Options.” *Technical Report NREL/TP-550-44586*.
- Rezaie, B., and M.A. Rosen. 2012. “District Heating and Cooling.” *Applied Energy* 93: 2–10.
- Schluck, T., P. Kräuchi, and M. Sulzer. 2015. “Non-Linear Thermal Networks.” 1–6.
- Schmidt, D. 2014. “EBC ANNEX 64 LowEx Communities,” 1–17.
- Stanford, Sustainable. 2015. “Fact Sheet: Green Buildings - Operations & Maintenance.”  
[https://sustainable.stanford.edu/sites/default/files/FactSheet\\_GreenBldgs\\_Operations.pdf](https://sustainable.stanford.edu/sites/default/files/FactSheet_GreenBldgs_Operations.pdf).
- Stegner, J. 2014. “Stanford Energy System Innovations: General Information.” Stanford.
- Torcellini, P., S. Pless, M. Deru, and D. Crawley. 2006. “Zero Energy Buildings: A Critical Look at the Definition.” *ACEEE Summer Study*.

UC Merced. 2016. "Facilities Management: Central Plant." <http://facilities.ucmerced.edu/central-plant>.

United States Census Bureau. 2010. "2010 Census Urban Area Facts." <https://www.census.gov/geo/reference/ua/uafacts.html>.

Weather Underground Inc. 2016. Accessed February 16. [www.wunderground.com](http://www.wunderground.com).