

Pushing the Envelope—Moving Dynamic Building Envelope Thermal Energy Storage Systems Mainstream

*Sven Mumme and Bandana Kar, US Department of Energy Building Technologies Office
Som S. Shrestha, Zhenglai Shen, and Daniel Howard, Oak Ridge National Laboratory
Ravi Anant Kishore and Chuck Booten, National Renewable Energy Laboratory*

ABSTRACT

This paper discusses two novel thermal energy storage–integrated dynamic building envelope technologies that are supported by the US Department of Energy Building Technologies Office. This study focuses on their ability to harvest ambient energy, improve energy efficiency by reducing HVAC loads and peak electricity demand, and enhance thermal resilience in buildings during heat waves and cold snaps that coincide with grid failure. The paper also discusses the recent advancements that have made these systems more affordable and easier to integrate into new and existing buildings.

The first solution is a thermally anisotropic building envelope system that can redirect ambient thermal energy (heat or coolness) from diurnal outdoor conditions, solar irradiance, and night-sky radiation from the envelope to a hydronic loop. The redirected thermal energy can be stored in a thermally anisotropic building envelope–integrated thermal energy storage system that can use the stored energy to offset HVAC energy use and peak demand. The second solution is an innovative plug-and-play thermal switch in the form of insertable plugs integrated with a phase change material. The plug can vary its thermal resistance based on indoor and outdoor conditions, thus allowing preferential directional heat flow and enhancing the use of ambient cooling and heating to charge and discharge the phase change material, much like a solid-state economizer. The first solution can be actively controlled to optimize the performance, and the second solution is passive, requires no external power, and works solely based on the ambient temperature.

Introduction

Out of approximately 40 quadrillion Btu (quads) of primary energy used in buildings in the United States, 15.5 quads, or 40%, of the energy used is attributable to heat transfer and air leakage through building envelope components (U.S. Department of Energy 2014). Globally, energy use for indoor temperature control is increasing faster than that of energy used in buildings for any other purpose (International Energy Agency (IEA) 2018). Considering that the United States has a goal to achieve a net-zero carbon economy by 2050 (The White House 2021), energy efficiency improvements in buildings can play an important role in achieving decarbonization objectives (US Dept. of Energy 2024). Although significant efforts have been made to improve the performance of building envelopes to reduce operational energy use and

Notice: This manuscript has been authored by UT-Battelle, LLC, under contract DE-AC05-00OR22725 with the US Department of Energy (DOE). The US government retains and the publisher, by accepting the article for publication, acknowledges that the US government retains a nonexclusive, paid-up, irrevocable, worldwide license to publish or reproduce the published form of this manuscript, or allow others to do so, for US government purposes. DOE will provide public access to these results of federally sponsored research in accordance with the DOE Public Access Plan (<https://www.energy.gov/doe-public-access-plan>).

associated CO₂ emissions, opaque envelopes currently used in buildings are mostly static (i.e., they do not allow harvesting thermal energy [heat or coolness], and heat transfer through building envelopes cannot be changed dynamically to fully benefit from favorable outdoor conditions such as diurnal temperature swing, night-sky radiation, or solar radiation).

To tap this opportunity, the US Department of Energy (DOE) is working with national labs and industry to develop dynamic building envelope technologies. The objective of this paper is to discuss two novel thermal energy storage (TES)-integrated dynamic building envelope technologies that are supported by the DOE Building Technologies Office. The studies focus on their ability to harvest ambient energy, improve energy efficiency by reducing HVAC loads and peak electricity demand, and enhance energy and thermal resilience in buildings. The first solution is a thermally anisotropic building envelope (TABE) system that can redirect ambient thermal energy from diurnal outdoor conditions, solar irradiance, and night-sky radiation from the envelope to a hydronic loop. The redirected thermal energy can be stored in a TES system, and the system can use the stored energy to offset HVAC energy use and peak demand. The second solution is an innovative plug-and-play thermal switch in the form of insertable plugs integrated with a phase change material (PCM). The plug can vary its thermal resistance based on indoor and outdoor conditions, thus allowing preferential directional heat flow and enhancing the use of free ambient cooling and heating to charge and discharge the PCM, much like a solid-state economizer. This paper also explores the recent advancements that have made these systems more affordable and easier to integrate into new and existing buildings.

This paper first presents the technical description, laboratory and field evaluations, energy savings, peak demand reduction, and enhanced resiliency potential of a TABE integrated with a TES system. It also discusses a scale-up manufacturing option for TABE panels. The paper then presents the design details of an innovative plug-and-play thermal switch, which has been specifically developed for retrofit applications in existing buildings. The plug-and-play thermal switch contains a thermal actuator that selectively opens and closes the two thermally conductive surfaces to provide variable thermal resistance inside the insulation based on the operating temperature.

TABE + TES System

Oak Ridge National Laboratory (ORNL) has developed the TABE to enhance the thermal management of a building envelope (Biswas et al. 2019a; b; Shrestha et al. 2020). The TABE allows heat dissipation in a preferential direction by embedding high-thermally conductive, thin metal sheets, such as aluminum foil, in a building envelope and connecting the conductive layers to hydronic loops. These hydronic loops enable the collection of natural thermal energy (heat in winter and coolness in summer) from diurnal weather conditions, solar irradiance in the winter, and night-sky cooling in the summer on the exterior side of the TABE roof or wall. The energy is stored in the TES system, which can be used later for building heating and cooling applications. The TES system consists of a tank containing a PCM, allowing high-energy density storage through latent heat. A fin-and-tube heat exchanger fitted in the TES tank and connected to the hydronic loops of the TABE enhances the energy transfer between the fluid (typically a water-glycol solution) circulating in the hydronic loops and the PCM. By regulating the flow rate in the TABE + TES system, the energy transfer to and from the storage medium can be controlled. Through laboratory and field evaluations (Biswas et al. 2019a; Howard et al. 2024), the authors have demonstrated that the TABE significantly reduced the cooling load by over 80% and the heating load by over 60% when it was connected to a regulated water bath that mimics the

thermal loop connected to a ground loop. Additionally, the authors have calibrated a finite element model of the TABE (Howard et al. 2023) and evaluated the demand-side management of the TABE + TES system using the calibrated models (Shen et al. 2024a).

Figure 1 provides an overview of the development stages of the TABE + TES system. It includes conceptual design, laboratory and field evaluation at the component level, and simulation and field evaluation at the building level. The TABE + TES system has three modes of operation: harvest, store, and deploy. Harvesting involves collecting thermal energy from the TABE and delivering it to the TES. Storage mode retains thermal energy within the TES without exchanging with TABE. Deployment releases the stored thermal energy from the TES to the building via TABE. In winter, thermal energy is harvested (heat absorption) from the environment via warm afternoons and solar radiation (the lowest heating demand period), stored, and released at night to meet the heating demand. In summer, the coolness (cooling energy) from night-sky radiation and low outdoor temperatures at night (the lowest cooling demand period) is collected (heat rejection from the PCM), stored in the TES, and released to the indoor space during the peak cooling demand. To optimize the collection and use of thermal energy, the TABE's exterior hydronic loop is used to collect heat in winter and coolness in summer, and the interior hydronic loop is used to release heat from the TES in winter and coolness in summer.

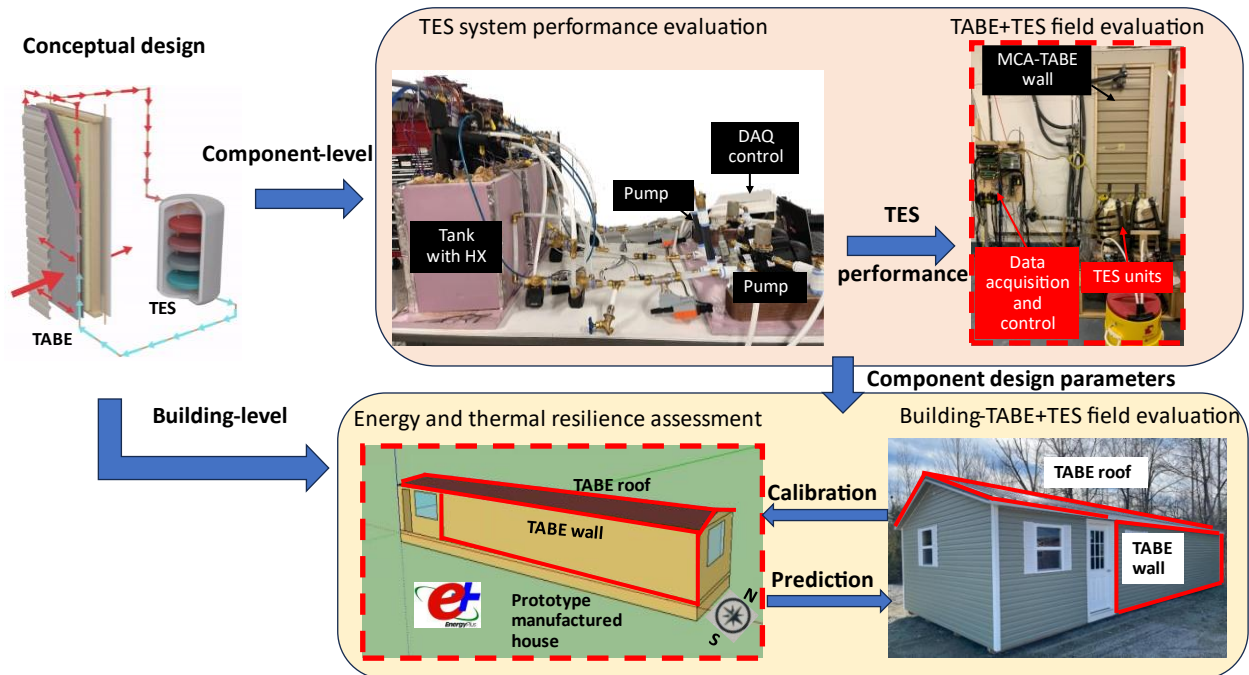

Figure 1. Overview of the TABE-integrated TES system from conceptual design to component-level and building-level evaluations.

To demonstrate the potential to harvest thermal energy from building envelopes, Figure 2 presents the hourly average exterior surface temperatures for a DOE prototype single-family residential building (U.S. Department of Energy 2018) in Los Angeles (LA), California, for four summer (June to September) and four winter (December to March) months. The building complies with the International Energy Conservation Code (IECC) 2012 (IECC 2012) requirement. Figure 2(a) shows that the hourly average exterior side of the wall and roof surface temperatures are lower than the indoor air temperature for 12 h/day in the summer, marked by the green-colored boxes. This period allows the collection of cooling energy. Figure 2(b) shows

that during winter, the exterior wall and roof surface temperatures are higher than the indoor air temperature for 8 h/day (gold-colored box), enabling the collection of heating energy. However, a mismatch exists between the availability of useful thermal energy and the building's peak demand. Therefore, a TAFE + TES is conceptualized to store the thermal energy from the TAFE and use the stored energy through the TAFE to offset HVAC energy use and peak demand.

Given the capability of the TAFE + TES system to harvest, store, and deploy thermal energy for both cooling and heating benefits to the building, this system can be targeted to reduce energy consumption and peak electricity demand from the building's HVAC sensible heating and cooling while also providing the benefit of thermal resilience to the building.

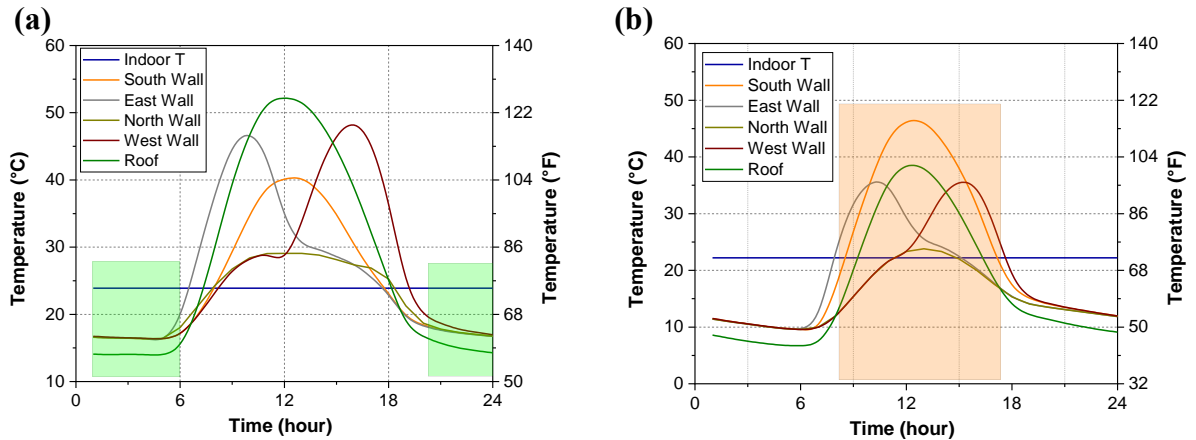

Figure 2. Average exterior surface temperature for a residential prototype building in LA during (a) summer (June to September) and (b) winter (December to March).

Performances Evaluation of a Manufactured House with the TAFE + TES System

Prototype manufactured house and retrofitting for the TAFE + TES system. The EnergyPlus model of prototype manufactured house (U.S. Department of Energy 2018) was used as the baseline building to evaluate the HVAC energy consumption and thermal resilience both before and after adopting the TAFE + TES system. The prototype building is a single-section, one-story building with the long side facing toward the south and a total floor area of 85.9 m² (924.3 ft²) (Figure 1). The building uses a ducted split system for cooling and an electrical furnace for heating with the set points of 22.2°C (72°F) and 23.9°C (75°F) for heating and cooling, respectively. Details of the HVAC system's efficiency and the envelope's thermal properties are summarized in Table 1.

The TAFE roof and wall panels were strategically incorporated to modify the baseline building. Only the roof and south-facing wall were modified to convert from baseline to TAFE assemblies. A 35-gallon TES tank with a latent energy storage capacity of 5.63 kWh was integrated with the TAFE thermal loops. PCM was used as the energy storage material with a latent heat capacity of 180 J/g and a density of 850 kg/m³. Two PCMs were used with a phase change temperature of 21°C for cooling and 26°C for heating (refer to Shen et al. 2024a for details of the PCM behavior). The building and TES modeled for this study mimic the integrated system being built by ORNL for a whole-house TAFE + TES field evaluation.

Table 1. Envelope thermal properties and HVAC system of the manufactured house

Category	Description
HVAC	<ul style="list-style-type: none"> • Cooling: Split system coefficient of performance (COP): 4.07 • Heating: Electric furnace COP: 1.0
Envelope thermal properties	<ul style="list-style-type: none"> • Roof: R-1.1, Ceiling: R-15.3, Exterior wall: R-9.4, Floor: R-18.5 (h·ft²·°F)/Btu • Window: U-6.1 W/m²·K, SHGC-0.7
TABE	<ul style="list-style-type: none"> • Roofs: South and north roofs have the same area, 43.4 m² (466.8 ft²), as the baseline • Wall: Only the south wall has an area of 35.9 m² (386.5 ft²)

Annual energy consumption and peak demand reduction. The whole-building HVAC energy of the baseline and the one with the TABE + TES system were assessed using EnergyPlus. Their thermal resilience was also examined in terms of resistance to heat wave and cold snap coincidence with a power outage in LA. The charging and discharging of TES units were controlled by a rule-based controller (details can be found in Shen et al. 2024a). The controller considered the cooling season (May–October) and heating season (November–April) based on the heating degree days and time of use (TOU) to reduce the peak electricity demand. The charging and discharging times in a day for the heating season and cooling season are specified in Table 2. The TOU was adopted from the LA Department of Water and Power (Los Angeles Department of Water and Power 2024). For a workday, these data include three TOU periods (i.e., Base from 8:00 p.m. to 10:00 a.m., Low Peak from 10:00 a.m. to 1:00 p.m. and 5:00 p.m. to 8:00 p.m., and High Peak from 1:00 p.m. to 5:00 p.m.).

Table 2. Charging and discharging times in a day for heating and cooling seasons

Seasons	TES charging/discharging time in a day
Heating season	<ul style="list-style-type: none"> • Charging time: 9:00 a.m.–6:00 p.m. • Discharging time: 12:00 a.m.–9:00 a.m. and 6:00 p.m.–12:00 a.m.
Cooling season	<ul style="list-style-type: none"> • Charging time: 12:00 a.m.–9:00 a.m. • Discharging time: 9:00 a.m.–12:00 a.m.

Figure 3 presents the HVAC heating and cooling loads of the baseline and TABE + TES system. Overall, the adoption of TABE + TES system reduced both heating and cooling loads. Specifically, the heating load decreased from a peak of 1.6 kW to around 1.2 kW, and the cooling load reduced from 3.4 kW to 2.3 kW, indicating a 32% reduction in HVAC size. The peak loads were determined as the 99.5th percentile of the annual cooling and heating demands, which is commonly used for HVAC sizing. It ensures the HVAC system can maintain comfortable indoor temperatures for nearly the entire year, except during the most extreme 0.5% of weather conditions, thereby balancing efficiency with performance.

The annual electricity consumption is summarized in Table 3. As expected, the adoption of the TABE + TES system significantly lowers the HVAC electricity consumption. Annually, it reduced the electricity consumption from 3,519 kWh to 2,049 kWh (including the operation of TABE + TES pumps, which consumed 243 kWh), representing a 42% energy consumption reduction. Also, the High Peak period electricity consumption reduced by 258 kWh (38%

reduction). The corresponding monthly HVAC electricity and peak electricity consumptions are shown in Figure 4. Evidently, the heating season (November–April) has higher monthly electricity savings than the cooling season (May–October) (Figure 4[a]). This result is attributed to the low efficiency of the electric furnace, which has a coefficient of performance (COP) of 1, but the cooling system (split system) is very efficient (COP = 4.07) to remove heat during the cooling season. The monthly High Peak TOU results [Figure 4(b)] show that the cooling season has a much larger electricity reduction than the results in the heating season. The larger reduction in the cooling season is because the discharging of TES matches with the High Peak period in the cooling season, although it does not match its counterpart in the heating season. This result also explains why the TABE + TES system had a higher electricity saving during the Base period (Table 3).

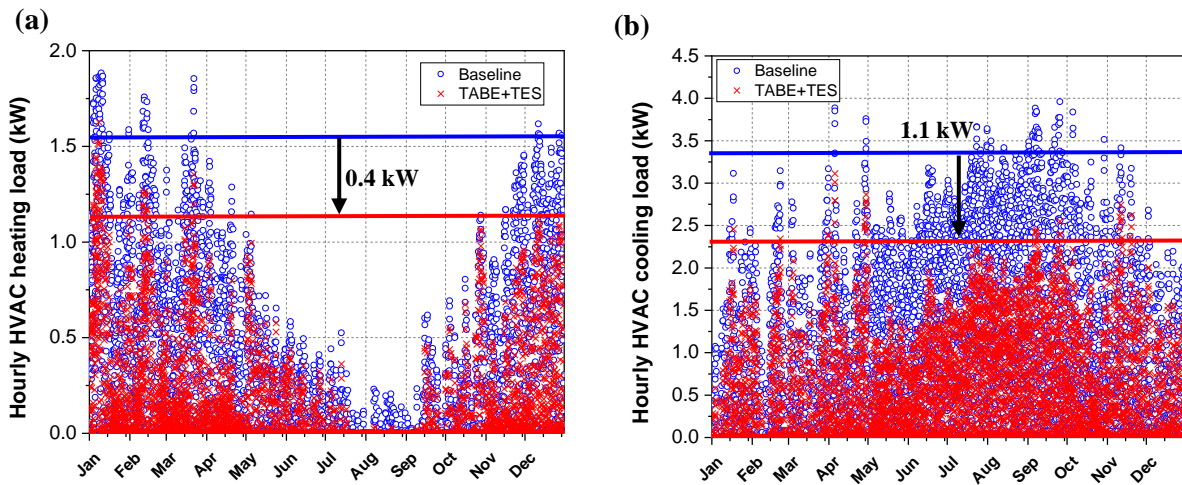

Figure 3. HVAC heating and cooling loads of the baseline and TABE + TES systems: (a) heating load and (b) cooling load.

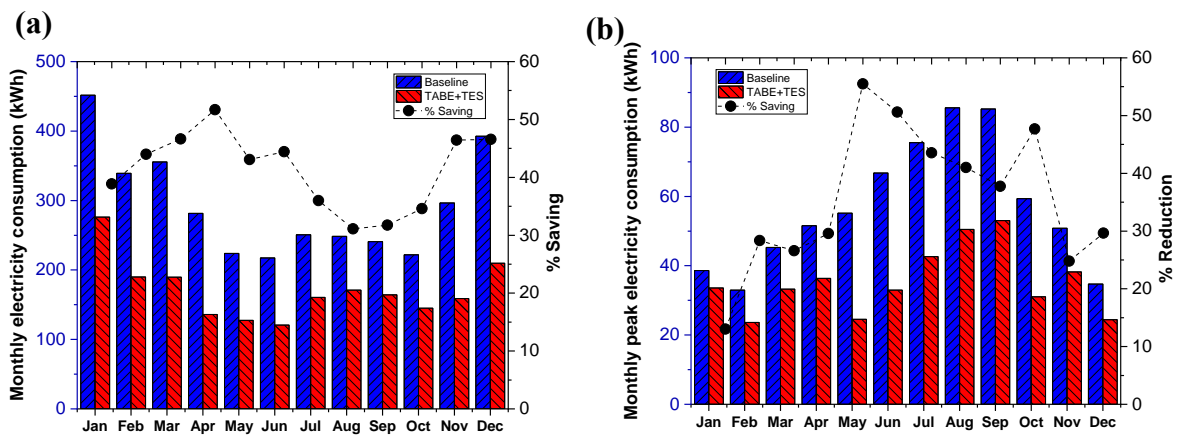

Figure 4. Monthly electricity and peak electricity consumption and demand as well as savings and reduction: (a) monthly electricity consumption and savings and (b) monthly High Peak–period electricity consumption and reduction.

Table 3. Annual HVAC Base, Low Peak, and High Peak periods' electricity consumption and savings

	Base	Low Peak	High Peak	Total
Baseline (kWh)	2,371	467	682	3,519
TABE + TES (kWh)	1,314	311	424	2,049
Savings (%)	45	33	38	42

Thermal resilience assessment. The thermal resilience was assessed by using a 3-day heat wave and cold snap. The method developed by Ouzeau et al. 2016 and extended by Shen et al. (Shen et al. 2024b) was used to identify heat waves and cold snaps from historical weather data. The method analyzes the mean daily temperature and uses three temperature thresholds to find the occurrence, start, and end of the extreme temperature event. Figure 5 shows the selected heat wave and cold snap in LA based on the historical weather data of 2008. The peak outdoor air temperature climbed to 38.5°C (101.3°F) during the heat wave and dropped to 2.5°C (36.5°F) during the cold snap.

The heat index and hour-of-safe (HOS) were used to quantify the thermal resilience of the baseline and TABE + TES systems during the selected heat wave and cold snap. The US Occupational Safety and Health Administration (OSHA) uses the heat index as an indicator to estimate heat stress (OSHA 2008). Additionally, HOS (Ayyagari et al. 2020) was adopted to estimate when the indoor air temperature reaches unsafe levels for various populations. The estimated heat index and indoor air temperature during the heat wave and cold snap are presented in Figure 6. Clearly, the TABE + TES system can enhance the thermal resilience by reducing the severity of an extreme-caution heat index [Figure 6(a)] while relieving the exposure of vulnerable people to an unsafe indoor environment during a cold snap [Figure 6(b)].

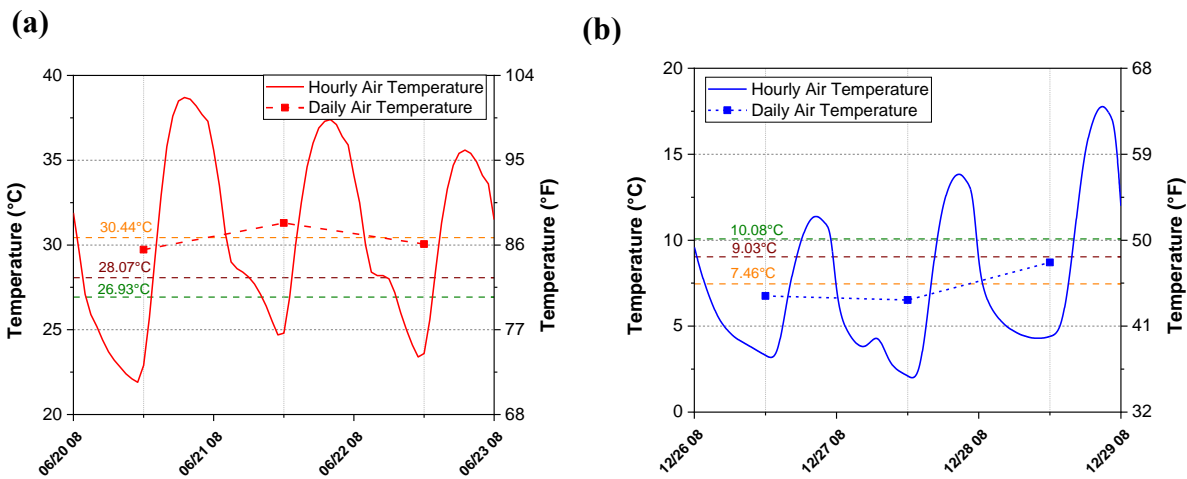

Figure 5. A 3-day heat wave and cold snap in LA: (a) heat wave and (b) cold snap. Dashed horizontal lines represent the temperature thresholds that the daily air temperature needs to meet to be identified as heat wave or cold snap, orange: peak temperature, red: occurrence temperature, green: start temperature.

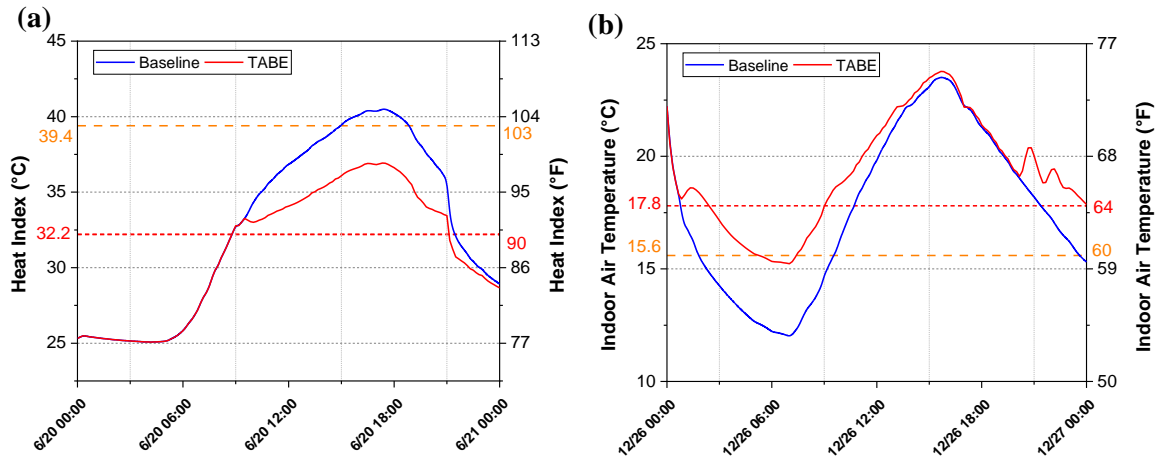

Figure 6. Heat index and indoor air temperature during the heat wave and cold snap coincidence with a 1-day power outage: (a) heat index and (b) indoor air temperature. Dashed horizontal lines represent the temperature thresholds to be categorized as (a) extreme caution during heat wave and (b) unsafe for vulnerable people and mild for healthy people.

Scale-Up Manufacturing of TABE and Field Evaluation of TABE + TES System

The high potential of the TABE + TES system to improve energy efficiency, reduce peak load, and enhance energy and thermal resiliency led to an investigation of a scalable and cost-effective avenue for the TABE. Insulated metal panels (IMPs) emerged as a promising candidate because of their highly conductive metal skins, which align to the need for TABE to efficiently collect and reject heat through hydronic loops. Prototype IMP-TABE panels were designed, constructed, and connected with TES. Currently, two panels are being evaluated (i.e., a metal panel containing TABE, called the Metal Construction Association [MCA]-2, and a baseline panel [MCA-B] identical to the TABE panel but without hydronic loops) are being evaluated at the Natural Exposure Test (NET) Facility in Charleston, South Carolina (see Figure 7). The MCA-2 panel is connected to two 5-gallon TES tanks to form the TABE + TES system.

The performance of the TABE panels is monitored using heat flux transducers to measure the heat transfer between the wall and the indoor space, thermistors to measure the temperature at various locations, and infrared turbine flow meters to measure the fluid flow rate. The hydronic loop is controlled by three-way flow control valves that allow the fluid flow to be altered between the TES and exterior or interior hydronic loops. The valves also allow the fluid flow rate to be controlled. The development of control strategies aims to optimize the charging and discharging of TES units. The field test results are expected to demonstrate the feasibility of the TABE + TES system and the scale-up manufacturing of IMP-TABE panels in an accessible and cost-effective manner.

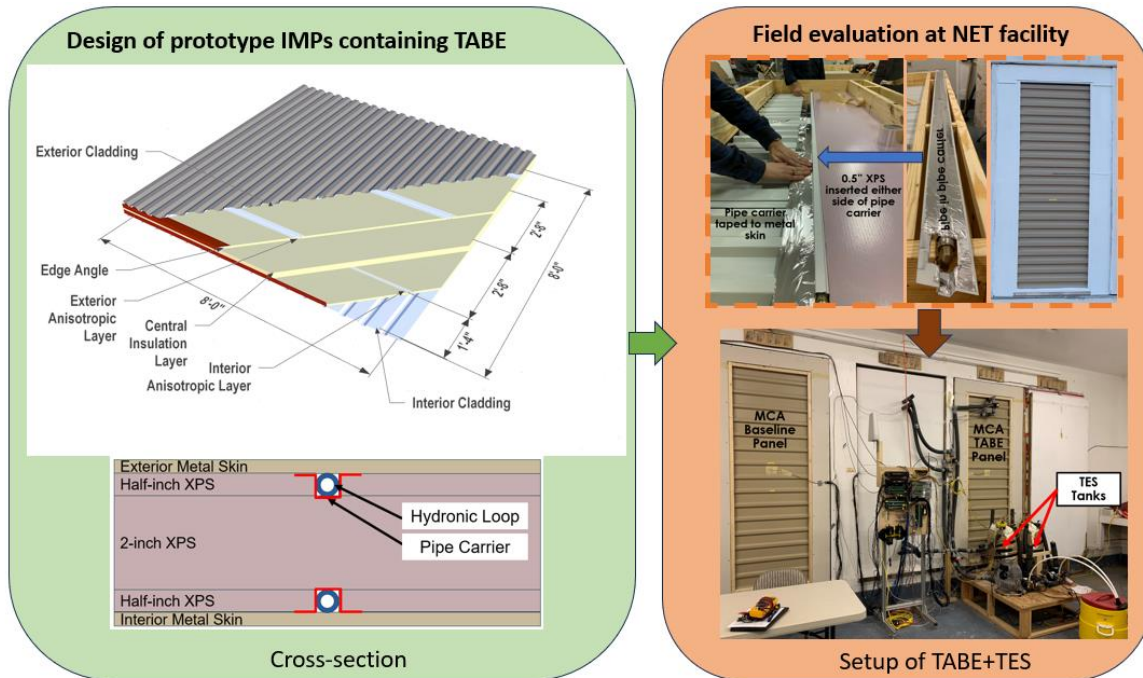

Figure 7. Prototype IMPs containing TABE (IMP-TABE), construction, and field evaluation of TABE + TES system at the NET Facility.

IMP Manufacturing of TABE Panels to Promote Accessibility and Affordability

Although the prototype panels being tested at the NET Facility closely resemble the IMP, their construction still relied on manual and labor-intensive processes. To advance the accessibility and affordability of TABE panels, a manufacturing process has been conceptualized that only needs to slightly modify the current IMPs manufacturing process (Figure 8). The standard IMP manufacturing process begins with two metal coils (one for each interior and exterior metal skin). The metal coils are roll-formed to both flatten the metal and to add the desired profiling to each skin. Then, the two metal skins are brought together closely, and foam is applied between them using a foaming-in-place technique. After passed through the heat-curing press in a continuous line, a traveling saw is used to cut each individual panel to size.

ORNL researchers are collaborating with the MCA to modify conventional IMPs to a TABE with minimum modification in production lines. This process involves inserting hydronic loops between the interior and exterior metal skins during foam application and then using the foaming-in-place technology to secure both the metal skins and the hydronic loops in the IMP structure.

Cost increases associated with TABE-equipped IMPs (over standard IMPs) are currently under estimation in collaboration with members of the industry partner MCA. Multiple factors contribute to the price differences, including panel-to-panel connections for hydronic loops and increased job-site labor during installation. A comprehensive review of the design details, manufacturing processes, and installation practices is planned to mitigate the increased costs. Moreover, the authors plan to conduct a cost-benefit analysis to assess the benefit offered by an IMP-TABE + TES system, including improved energy efficiency, reduced peak load, and enhanced energy and thermal resilience.

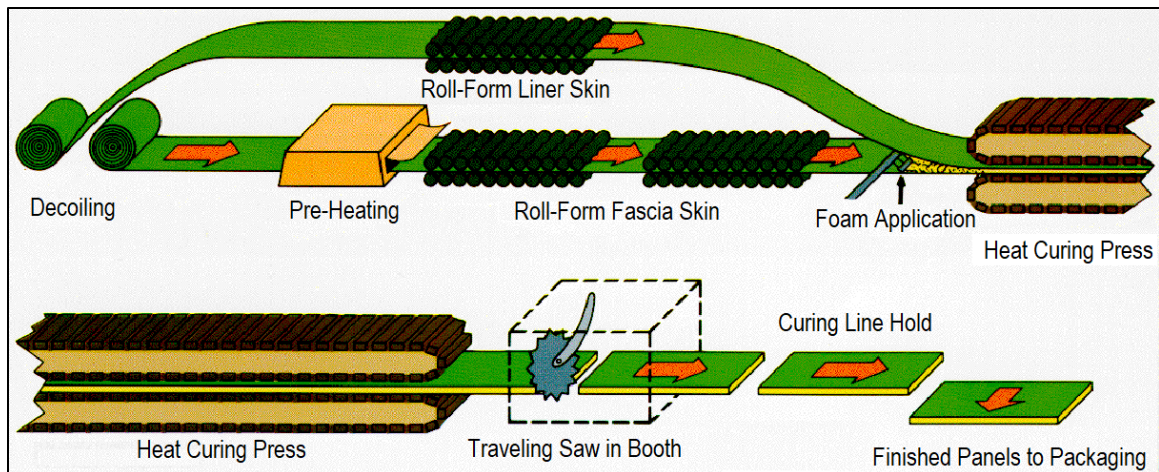

Figure 8. Continuous-line (foaming-in-place) IMP manufacturing process. Figure Source: MCA.

Plug-and-Play Thermal Switches

Unlike their electrical counterparts, directional control devices for heat transfer, such as thermal diodes, regulators, and switches, are not widely used, particularly at a large scale, such as in buildings. These devices can modify the heat flow depending on the temperature of the system and the magnitude and direction of the thermal gradient. As described in review articles (Wehmeyer et al. 2017; Wong et al. 2021), fundamental differences exist between the operation of a thermal diode, thermal regulator, and thermal switch. These terms, however, are used interchangeably in the literature; thus, this paper refers to them as the *thermal switch*.

A thermal switch exhibits an adjustable thermal conductance; in other words, the heat transfer rate through the thermal switch is different when it is at a low-conductance (“OFF”) state versus when it is at a high-conductance (“ON”) state. In some cases, the existence of ON and OFF states is governed by the intrinsic material properties, which can be different based on the operating temperature or temperature bias. However, in other cases, the states are achieved using external excitation such as ultraviolet radiation, electric or magnetic fields, electrical heating, or mechanical stress or pressure (Hagen et al. 2007; Rodrigues et al. 2019).

In previous studies, Kishore et al. (2021) and Kommandur and Kishore (2023) from the National Renewable Energy Laboratory described how the thermal switches can be used to achieve an operational dynamic wall, which when combined with a PCM layer, can provide a 15%–72% reduction in wall-related annual heat gain and a 7%–38% reduction in wall-related annual heat loss. Other studies have reported that using switchable envelopes, which have variable resistance such as thermal switches, can reduce HVAC thermal load by up to 42% in residential buildings (Menyhart and Krarti 2017) and up to 17% in commercial buildings (Shekar and Krarti 2017). One of the operational designs of thermal switches for the dynamic building envelope was demonstrated by Miao et al. (Miao et al. 2022). The authors used a pair of shape memory alloy wires to achieve a bistable snap-through mechanism of a metallic beam that reversibly connected and disengaged between the two conducting plates, causing the variation in thermal conductance or, simply, thermal switching. This thermal switch was voltage-actuated and exhibited a switch ratio (ratio between on- and off-state thermal conductivities) of approximately 12 and an off-state thermal conductivity of 0.045 W/(m·K), which is comparable with fiber glass insulation. Another promising design of a solid-state thermal switch for a

dynamic building envelope was introduced by Iffa et al. (2022) and Kunwar et al. (2023), who employed a direct-current motor to connect and disengage two metallic U-channels placed between the insulation panels. Thermal bridging provided by U-channels between the conductive and resistive states was reported to provide a switching ratio up to 7.5.

Although the thermal switches described here have been designed for building applications, they are active devices that require electric power to operate. This section describes a wax motor-actuated thermal switch for building envelopes similar to the paraffin-actuated thermal switches that have been explored for space applications (Sunada et al. 2002b; a).

Error! Reference source not found. Figure 9 depicts the working principle of the thermal switch that consists of two thermally conductive (aluminum) cylinders, concentrically stacked with an insulating (polycarbonate) cylindrical spacer. A thermally conductive connector (aluminum) is inserted inside the three cylinders and slides to provide the required switching mechanism. In the OFF state (i.e., low-conductance configuration), the connector is located to contact the lower aluminum cylinder and the polycarbonate cylinder. The path of least thermal resistance to heat flow includes the low-thermal conductivity polycarbonate with, consequently, an overall low conductance. In the ON state (i.e., high-conductance configuration), the connector is moved up to connect with the aluminum cylinders. The path of least thermal resistance to heat flow in this case contains the high-thermal conductivity aluminum cylinders, therefore resulting in an overall high conductance (Kommandur and Kishore 2023). The movement of the inner cylinder is controlled by a preselected wax motor that has an actuation temperature of approximately 20°C ; therefore, when the temperature is $>20^{\circ}\text{C}$, wax melts and expands, whereas when the temperature is $<20^{\circ}\text{C}$, wax solidifies and contracts. Two different designs are possible based on the nature of the climatic conditions. Figures 9(a) and 9(b) depict designs for cold and hot climates.

This thermal switch design is suitable for retrofit applications because it can be inserted into existing building envelopes by creating small holes (about an inch in diameter). The design is passive in nature, requires no external power, and works solely based on ambient temperature. Additionally, the plug-and-play design allows existing insulation to remain in place and facilitates insertion of these switches in the building envelopes using simple processes such as drilling, plugging, and sealing. Thermal switch construction is also simply, scalable, and requires common materials such as a few aluminum tubes, an aluminum rod, and a wax motor.

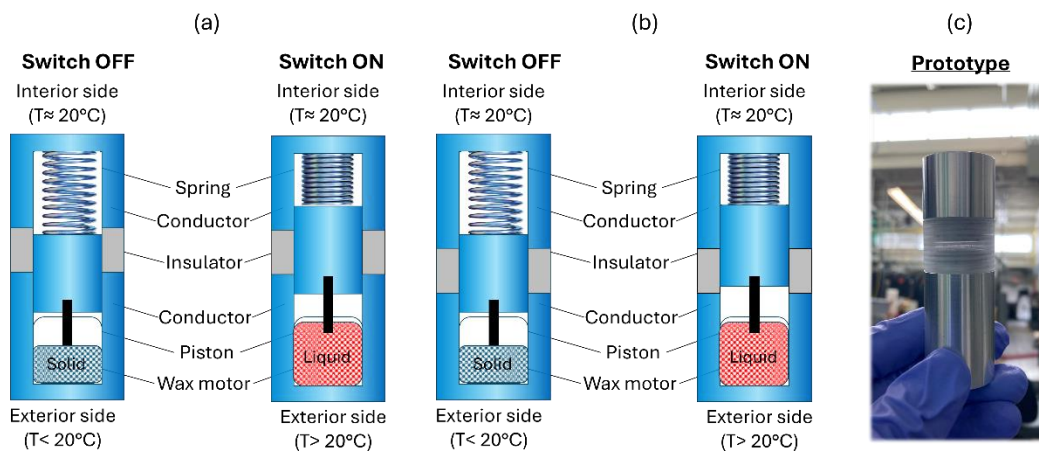

Figure 9. The working principle of the thermal switch in (a) a cold climate, (b) a hot climate, and (c) the laboratory prototype.

Figure 10 shows the experimental prototypes containing one (left) and more than one (middle) thermal switch into a single insulation panel. Preliminary experimental results from using a 10 × 10 in. (25.4 × 25.4 cm) insulation panel comprising of one thermal switch demonstrate an effective switching ratio of approximately 6 with an effective off-state thermal conductivity of approximately 0.05 W/(m·K). The effective thermal conductivity of the thermal switch–integrated insulation panel can be increased by increasing the number of switches per unit area. The preliminary analysis suggests that the on-state thermal conductivity increases linearly with the increase in the number of switches per unit area; however, this method leads to a linear increase in off-state thermal conductivity, as well. Additionally, the higher number of switches would result in a higher cost of the dynamic wall. Therefore, using more than a few switches per square foot of envelope surface area is not recommended.

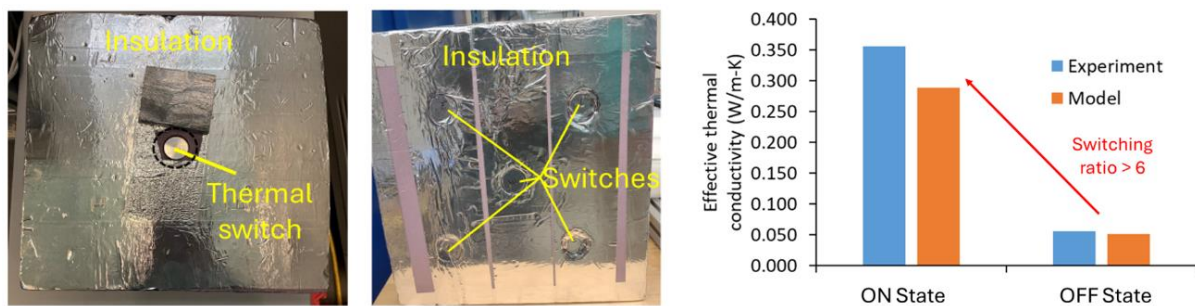

Figure 10. Experimental prototypes exploring the scalability of the thermal switches, along with preliminary experimental results demonstrating effective thermal conductivity for a 10 × 10 in. (25.4 × 25.4 cm) insulation panel comprising a single thermal switch.

Previous studies have suggested that thermal switches, when combined with a PCM layer in building envelopes, provide better thermal performance and energy savings than PCM-integrated static envelopes. A PCM layer can be in the middle of a wall cavity with a set of thermal switches on its two sides. In the summer season, for instance, ambient cooling during the nighttime allows thermal switches on the exterior side to transition to on-state, thereby solidifying the PCM based on its transition temperature. Later during the day, interior switches activate, allowing the PCM to discharge and thereby providing passive cooling. Modeling results show that depending on the climate, the PCM switch–integrated dynamic envelopes could provide a 15%–72% reduction in annual heat gain and a 7%–38% reduction in annual heat loss with one thermal switch per square foot of the envelope area. Additionally, the construction of these thermal switches is thoughtfully designed to be simple and scalable. For installation at large, only common materials are required, such as a few aluminum tubes, an aluminum rod, and a wax motor. The wax motor undergoes a phase transition to provide the required switching mechanism, and although the switching time can vary based on the available temperature difference, the activation time needed for the piston movement to switch from the off to on state or vice versa is approximately 2–3 min after the wax motor reaches the transition temperature. The plug-and-play design allows existing insulation to remain in place, providing minimal disruptions to existing buildings as well as occupants, which is typically challenging for any new retrofit technology. For new constructions, the commercial product is envisioned to be a panelized, switchable insulation board with built-in thermal switches, requiring no or minimal changes in the on-site installation processes.

Notably, the current version of the thermal switch is primarily designed for passive applications to maximize free ambient cooling and heating as an economizer to reduce a building's thermal load. The thermal switch design can be easily modified to operate as an active system that can allow more operation control that would be needed for load shifting and resilience. One key feature of active thermal switches is that they permit heat flow only when they are activated; therefore, the stored thermal energy in the PCM-integrated envelopes can be locked with minimal scope for leakage. This method can be used pragmatically for demand response, load shifting from peak to off-peak hours, and providing passive cooling and heating as a retrofit measure during extreme weather events, such as heat waves and winter storms, concurrent with power outages. Given that such design is beyond the scope of this study, details on active thermal switches and their application for load shifting and resilience will be presented in future studies.

Discussion: Policy Implications

Building envelope is the main barrier between interior and exterior environments and responsible for maintaining indoor temperature, occupants' thermal comfort, and reducing buildings' energy consumption. The envelope technologies discussed herein have the potential to leverage diurnal temperatures to maintain indoor thermal comfort during extreme events like heatwaves and winter storms while maintaining demand flexibility and improving buildings' energy and thermal resilience (Harris et al. 2021; Hong et al. 2023). Widespread adoption of these technologies can reduce energy burden of disadvantaged communities, improve their resilience, and meet decarbonization needs within the building sector (US Dept. of Energy 2024).

The 2021 International Energy Conservation Code (IECC) calls for increased R-values and U-values of the building envelope while accounting for climatic zones to increase efficiency and reduce energy consumption (IECC 2012). Likewise, the American Society of Heating, Refrigerating and Air-Conditioning Engineers (ASHRAE) Standard 90.1 – the second code that sets the standards for building energy use in the U.S. – has provided guidelines to increase R-values of insulation used in building envelopes (attics, slabs, walls). While these codes will benefit newer buildings, with 44% of the U.S. residential building stock being older than 1970, it is crucial to develop technologies for older homes to meet energy efficiency, thermal resilience, and demand flexibility needs. From a policy perspective, it is crucial to answer the following questions to ensure the widespread adoption of these novel technologies.

1. **Cost effectiveness:** determine the cost effectiveness of using these technologies among different income groups based on production and installation costs.
2. **Feasibility of deployment:** determine to what extent these technologies can be deployed in both newer and older buildings with minimum disruption to the occupants.
3. **Codes and standards:** evaluate to what extent these technologies can be used to meet building envelope standards pertaining to energy efficiency.

Conclusion

With buildings accounting for 40% of primary energy use in the US, building envelope technologies play a key role in the nation's energy portfolio and help manage energy consumption in buildings. Although significant efforts have been made to improve the performance of building envelopes to reduce operational energy use and associated CO₂ emissions, opaque envelopes currently used in buildings are mostly static (i.e., they do not allow

harvesting thermal energy, and heat transfer through building envelopes cannot be changed dynamically to benefit from outdoor conditions such as diurnal temperature swing, night-sky radiation, or solar radiation).

This paper presented two novel envelope technologies that can be integrated with TES systems to harvest natural thermal energy from the building envelopes. The results presented in this paper demonstrate that these technologies can reduce the building's heating and cooling energy use, reduce peak electricity demand, and enhance thermal comfort during a heat wave or cold snap that coincides with grid failure (i.e., the building's resiliency).

The first technology presented is the TABE integrated with TES systems that can harvest natural thermal energy from the exteriors of roofs and walls, store the energy in TES systems, and use the stored energy at a later time based on the building's energy demand. A hydronic loop connected to the TABE integrated with TES system uses pump power to activate the hydronic loop to transport thermal energy. This active thermal energy enabled by the hydronic loop requires only a fraction of power compared with a conventional HVAC system. Therefore, the TABE integrated with TES system can be used during grid failure with a backup generator or a battery to regulate indoor temperatures and reduce adverse heat exposure effects.

The second technology focused on thermal switches provides a passive, scalable, cost-effective, retrofittable solution to reduce the energy use in existing buildings and enhance occupants' thermal comfort. The plug-and-play design of the thermal switches allows inserting the technology into an existing envelope by drilling holes, followed by plugging and sealing. Because of its passive nature, the device requires no external power and works solely based on the ambient conditions.

Acknowledgments

This work was supported by the DOE Office of Energy Efficiency and Renewable Energy's Building Technologies Office. A portion of the research used resources at the Building Technologies Research and Integration Center, a DOE-designated National User Facility operated by the Oak Ridge National Laboratory.

A member industry of the Metal Construction Association provided the metal panels for this study and collaborated to develop the TABE with a minimum cost premium. The authors acknowledge the help from MCA and technical advice from Robert Zabcik and Jeff Henry.

The work presented in this paper is partly funded by Stor4Build, which is a multi-lab consortium funded by the US Department of Energy Building Technologies Office to accelerate equitable solutions in thermal energy storage technologies for buildings.

This work was authored in part by the National Renewable Energy Laboratory, operated by Alliance for Sustainable Energy, LLC, for the U.S. Department of Energy (DOE) under Contract No. DE-AC36-08GO28308. The views expressed in the article do not necessarily represent the views of the DOE or the U.S. Government. The U.S. Government retains and the publisher, by accepting the article for publication, acknowledges that the U.S. Government retains a nonexclusive, paid-up, irrevocable, worldwide license to publish or reproduce the published form of this work, or allow others to do so, for U.S. Government purposes.

References

Ayyagari, S., M. Gartman, and J. Corvidae. 2020. *Hours of Safety in Cold Weather: a Framework for Considering Resilience in Building Envelope Design and Construction*.

- Biswas, K., S. Shrestha, D. Hun, and J. Atchley. 2019a. “Thermally Anisotropic Composites for Improving the Energy Efficiency of Building Envelopes.” *energies*, 12 (19): 195–209. <https://doi.org/https://doi.org/10.3390/en12193783>.
- Biswas, K., S. Shrestha, D. Hun, and J. Atchley. 2019b. “Thermally Anisotropic Composites for Heat Redirection and Thermal Management in Building Envelopes.” *2019 Therm. Perform. Exter. Envel. Whole Build. XIV Int. Conf.* Clearwater, Florida.
- Hagen, S., F. Leyssner, D. Nandi, M. Wolf, and P. Tegeder. 2007. “Reversible switching of tetra-tert-butyl-azobenzene on a Au(1 1 1) surface induced by light and thermal activation.” *Chem. Phys. Lett.*, 444 (1–3): 85–90. <https://doi.org/10.1016/j.cplett.2007.07.005>.
- Harris, C., S. Mumme, and K. Sawyer. 2021. *Opaque Envelopes: Pathway to Building Energy Efficiency and Demand Flexibility*.
- Hong, T., J. Malik, A. Krelling, W. O’Brien, K. Sun, R. Lamberts, and M. Wei. 2023. “Ten questions concerning thermal resilience of buildings and occupants for climate adaptation.” *Build. Environ.*, 244 (July). Elsevier Ltd. <https://doi.org/10.1016/j.buildenv.2023.110806>.
- Howard, D., S. Shrestha, Z. Shen, and T. Feng. 2024. “Field Evaluation and Numerical Study to Determine the Energy Saving Potential of Thermally Anisotropic Building Envelope.” *J. Build. Perform. Simul.*
- IECC. 2012. *International Energy Conservation Code: Residential Energy Efficiency*.
- Iffa, E., M. Salonvaara, N. Kunwar, S. Shrestha, P. Boudreaux, and D. Hun. 2022. “Development and Performance Evaluation of Active Insulation Systems using Solid-State Thermal Switches.” *Build. XV Conf.*, 294–301. Clearwater, Florida: ASHRAE.
- International Energy Agency (IEA). 2018. *The Future of Cooling: Opportunities for Energy-Efficient Air Conditioning*. Paris, France.
- Kishore, R. A., M. V. A. Bianchi, C. Booten, J. Vidal, and R. Jackson. 2021. “Enhancing building energy performance by effectively using phase change material and dynamic insulation in walls.” *Appl. Energy*, 283 (August 2020): 116306. Elsevier Ltd. <https://doi.org/10.1016/j.apenergy.2020.116306>.
- Kommandur, S., and R. A. Kishore. 2023. “Contact-Based Passive Thermal Switch with a High Rectification Ratio.” *ACS Eng. Au*, 3 (2): 76–83. <https://doi.org/10.1021/acsengineeringau.2c00046>.
- Kunwar, N., M. Salonvaara, E. Iffa, S. Shrestha, and D. Hun. 2023. “Performance assessment of active insulation systems in residential buildings for energy savings and peak demand reduction.” *Appl. Energy*, 348 (October): 1–7. <https://doi.org/10.1016/j.apenergy.2023.121209>.
- Los Angeles Department of Water and Power. 2024. “Residential Electric Rates.” Accessed March 5, 2024. <https://www.ladwp.com/account/customer-service/understanding-your->

rates/residential-electric-rates.

Menyhart, K., and M. Krarti. 2017. “Potential energy savings from deployment of Dynamic Insulation Materials for US residential buildings.” *Build. Environ.*, 114: 203–218. Elsevier Ltd. <https://doi.org/10.1016/j.buildenv.2016.12.009>.

Miao, R., R. Kishore, S. Kaur, R. Prasher, and C. Dames. 2022. “A non-volatile thermal switch for building energy savings.” *Cell Reports Phys. Sci.*, 3 (7): 100960. The Author(s). <https://doi.org/10.1016/j.xcrp.2022.100960>.

OSHA. 2008. *Using the Heat Index: A Guide for Employers Introduction*.

Ouzeau, G., J. M. Soubeyroux, M. Schneider, R. Vautard, and S. Planton. 2016. “Heat waves analysis over France in present and future climate: Application of a new method on the EURO-CORDEX ensemble.” *Clim. Serv.*, 4: 1–12. The Authors. <https://doi.org/10.1016/j.cliser.2016.09.002>.

Rodrigues, C., M. M. Dias, L. Martins, D. J. Silva, J. P. Araújo, J. C. R. E. Oliveira, A. M. Pereira, and J. Ventura. 2019. “A magnetically-activated thermal switch without moving parts.” *Energy Convers. Manag.*, 197 (July): 111881. Elsevier. <https://doi.org/10.1016/j.enconman.2019.111881>.

Shekar, V., and M. Krarti. 2017. “Control strategies for dynamic insulation materials applied to commercial buildings.” *Energy Build.*, 154: 305–320. Elsevier B.V. <https://doi.org/10.1016/j.enbuild.2017.08.084>.

Shen, Z., D. Howard, D. Hun, S. Mumme, and S. Shrestha. 2024a. “Coupling thermal energy storage with a thermally anisotropic building envelope for building demand-side management under various US climate conditions.” <https://doi.org/http://dx.doi.org/10.2139/ssrn.4743028>.

Shen, Z., S. Shrestha, D. Howard, D. Hun, S. Mumme, and B. Kar. 2024b. “Thermal Resilience of Residential Building with Thermally Anisotropic Building Envelope Connected to Geothermal Sources.” *ASHRAE 2024 Winter Conderence*. Chicago.

Shrestha, S., K. Biswas, D. Hun, and J. Atchley. 2020. “Thermally Anisotropic Composites for Thermal Management in Building Environments.” USA.

Sunada, E., K. Lankford, M. Pauken, K. S. Novak, and G. Birur. 2002a. “Wax-actuated heat switch for Mars surface applications.” *AIP Conf. Proc.*, 211–213.

Sunada, E., M. Pauken, K. Novak, C. Phillips, G. Birur, and K. Lankford. 2002b. “Design and flight qualification of a paraffin-actuated heat switch for Mars surface applications.” *SAE Tech. Pap.*, (724). <https://doi.org/10.4271/2002-01-2275>.

The White House. 2021. “FACT SHEET: The Bipartisan Infrastructure Deal Boosts Clean Energy Jobs, Strengthens Resilience, and Advances Environmental Justice.” *US Gov.* <https://www.whitehouse.gov/briefing-room/statements-releases/2021/11/08/fact-sheet-the->

bipartisan-infrastructure-deal-boosts-clean-energy-jobs-strengthens-resilience-and-advances-environmental-justice/.

U.S. Department of Energy. 2018. "Prototype Building Models." Accessed October 25, 2022. <https://www.energycodes.gov/prototype-building-models>.

US Department of Energy. 2014. *Windows and Building Envelope Research and development: Roadmap for Emerging Technologies*.

US Department of Energy. 2024. *Decarbonizing the U.S. Economy by 2050 - A National Blueprint for the Building Sector*. <https://www.energy.gov/eere/articles/decarbonizing-us-economy-2050>

Wehmeyer, G., T. Yabuki, C. Monachon, J. Wu, and C. Dames. 2017. "Thermal diodes, regulators, and switches: Physical mechanisms and potential applications." *Appl. Phys. Rev.*, 4 (4). <https://doi.org/10.1063/1.5001072>.

Wong, M. Y., C. Y. Tso, T. C. Ho, and H. H. Lee. 2021. "A review of state of the art thermal diodes and their potential applications." *Int. J. Heat Mass Transf.*, 164. <https://doi.org/10.1016/j.ijheatmasstransfer.2020.120607>.